

Electromechanical cylinders

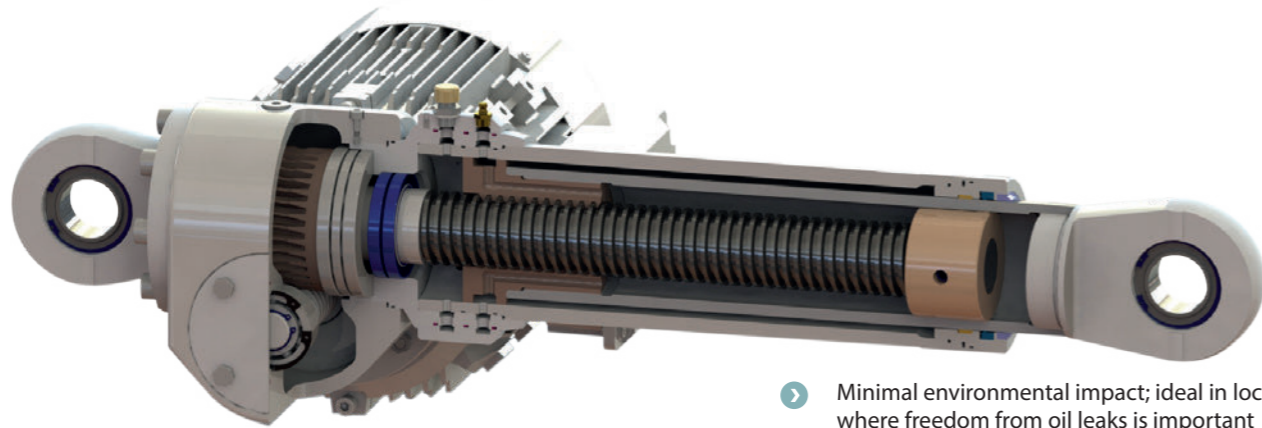

THOUSANDS OF STANDARD SOLUTIONS FOR ELECTROMECHANICAL CYLINDERS

Swedrive has a wide standard range with four different sizes for handling dynamic loads of up to 250 kN. We offer standard cylinders with strokes of up to 2300 mm and the ability to operate at speeds of up to 6000 mm/minute.



- Minimal environmental impact; ideal in locations where freedom from oil leaks is important
- Low noise level
- Energy is only required during motion
- Minimal rebound, easy to secure against unwanted movement during static loading
- Precise positioning and repeatability
- Easy to control desired travel and actuation time
- Speed is independent of load and direction of force
- Fast and easy installation
- Ability to operate multiple cylinders in parallel with the aid of mechanically or electrically operated shafts
- Fully enclosed design enables use in a variety of difficult environments
- Minimal servicing requirements

Quality, speed and flexibility

The hallmark of all our products is their high quality combined with our company's active technical development. As a result we can now also offer a completely new series of energy-efficient and cost-optimized electromechanical cylinders.

Electromechanical cylinders are taking over the market

Electromechanical cylinders from Swedrive are replacing the pneumatic and hydraulic cylinders that have dominated the market in linear movement for many years.

Today, our cylinders can be found in the defence industry, pulp and paper industry, materials handling, shipbuilding, medical applications, and other areas where total reliability in harsh environments is a key requirement.

There are many more arguments in their favour ➤

OUR CUSTOM SOLUTIONS ARE NO EXCEPTION, ON THE CONTRARY

Swedrive has a modular standard range with thousands of combinations that can effectively be used to further adapt and tailor customer-specific solutions.

By combining our know-how with yours we can develop the right solution

As a customer you benefit greatly from our breadth of know-how and long experience in designing and manufacturing cylinders. Based on your knowledge of the specific application needs we develop the solutions that suit your requirements.

This collaboration also results in a product that is optimized for technical performance, energy efficiency, integration dimensions, serviceability and environmental performance, and ensures we achieve the best total cost.



Customer-specific and custom-built

Our breadth of know-how and long experience are two key elements of our unique offering that have led to thousands of different variants, special modifications, products and solutions. They also give you reassurance as a customer.



Swedrive AB manufactures electromechanical cylinders, worm gear drives, screw jacks and high-quality custom solutions for industry. Swedrive is part of the Dacke Industry AB.

www.swedrive.se

Use the QR code or visit our website to learn more about the company and to download our catalogues of standard products.

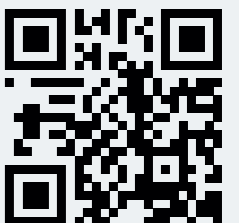

SWEDRIVE AB

Box 4
SE-341 02 Lagan, Sweden

Visiting address:
Prästtorpsvägen 14
SE-341 51 Lagan, Sweden
Tel.: +46 (0)372-265 00
E-mail: info@swedrive.se
www.swedrive.se